

EN



INSTALLATION GUIDELINES

INSTALLATION/SERVICING/MAINTENANCE/SAFETY ADVICE



DEL 

WINDER

NEPTUNE MANUEL

CONTENTS

PLEASE READ THESE INSTRUCTIONS CAREFULLY AND KEEP THEM FOR FUTURE REFERENCE

Please read this manual carefully to help you understand all of the information and to ensure safe installation, use and servicing. We cannot be held liable for any damage arising due to a failure to respect the instructions set out in this manual.

DESCRIPTION.....	p. 3
Components provided	p. 3
Tools required for assembly.....	p. 4
Packing list	p. 4
INSTALLATION.....	p. 5
Rewinder assembly and fastening.....	p. 5
SERVICING/MAINTENANCE.....	p. 6
Water level in pool.....	p. 6
Water filtration and treatment	p. 6
Servicing (customer's responsibility)	p. 6
Maintenance	p. 7
SAFETY ADVICE AND STANDARDS	p. 8
RECYCLING	p. 10

DESCRIPTION

COMPONENTS PROVIDED







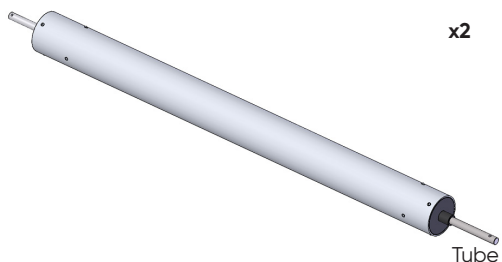

x1



x1

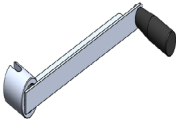

x2

 <p>x8 TBHC Screw M5 x 20</p>	 <p>x2 Fastening pin Ø10</p>	 <p>x4 Clamping ring</p>	 <p>x2 Crank handle</p>
 <p>x4 THPF Screw M8 x 90</p>	 <p>x4 dome cap nut M10</p>	 <p>x4 STHC Screw M8x20</p>	

Bag of loose fittings

DESCRIPTION

TOOLS REQUIRED FOR ASSEMBLY

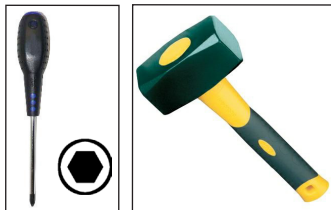

PACKING LIST

Example – for a 5.00 x 10.00m pool with roman stairs

Tube support : 1.20 x 1.00 x 0.50m/50kg - pallet

Tube : 0,15 x 0,15 x 5,10 m / 36 kg - 2 Packing

Poids total : 86 kg

ASSEMBLY



2 persons



3 hours

INSTALLATION

REWINDER ASSEMBLY

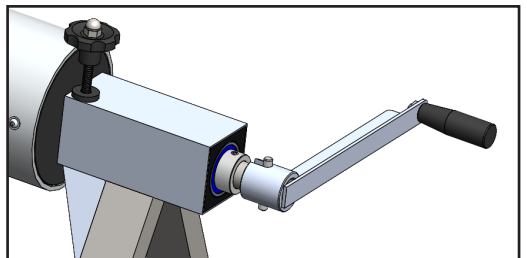
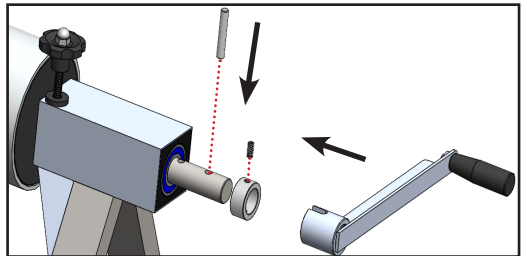
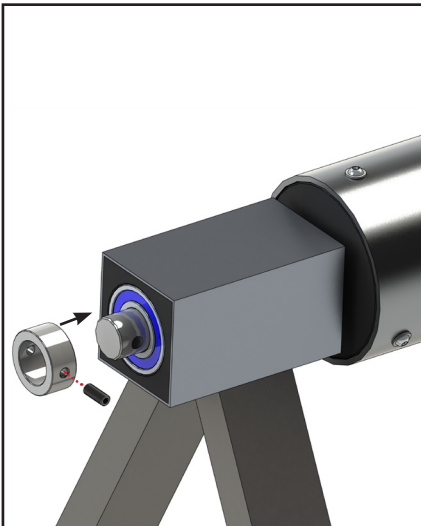
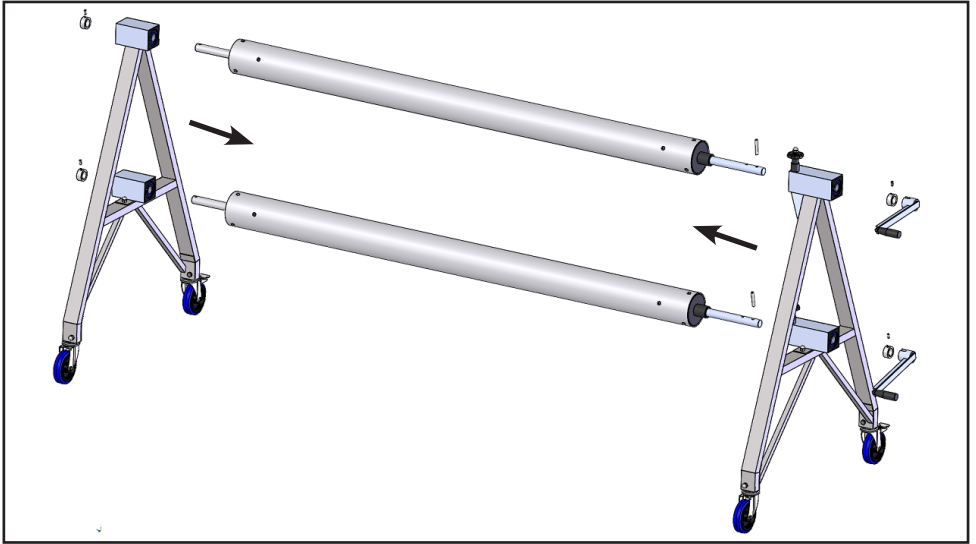

SERVICING/MAINTENANCE

Any person carrying out work on the electrical parts must be qualified and they must comply with the manufacturer's instructions in addition to the applicable standards and regulations.



During any intervention, the technician must wear PPE (personal protective equipment): gloves, goggles, mat, etc...

We recommend that the installation be disconnected from the power prior to any intervention taking place.

WATER LEVEL IN POOL

- In order to ensure maximum safety and correct operation of the rewinder, always check that the water level in the pool remains constant and complies with the manufacturer's requirements (for greater comfort, use an overflow and a water level regulator).
- A water level that is too high is due to the overflow being obstructed by leaves or other items.
- A water level that is too low means that there is a risk of blockage.
- In case of a recess or a handrail, the water level must be controlled by a level regulator.

WATER FILTRATION AND TREATMENT

- Programme filtration to take place at a time when the sun is shining on the pool and ensure that it is set to work all the time when the water reaches 25°C.
- In order to ensure that your installation will last, the water in the pool must be correctly treated in compliance with the applicable standards and recommendations (NF EN 16713-3).
- The pH, hardness and alkali levels of the water must be checked and adjusted as often as is necessary (although you will need to ensure that you don't correct these three parameters independently of each other but do so using the Taylor table and provide the water with balance with regard to the three parameters analysed).

SERVICING (customer's responsibility)

- Carry out a deep clean of the cover twice per year (the first time in the year it is used and prior to Wintering). This is even more important if the water in the pool is hard. In this case, use a descaling cleaning product (see catalogue) and rinse using a hose.
- It is best to inspect the entire system if the cover is forced to bear unexpected weight at any time (fall).
- Carry out an annual check of the straps.
- Do not wash the IPE decking with a pressure washer, we recommend that you clean them regularly using water and a non-metallic brush.

SERVICING/MAINTENANCE

MAINTENANCE (ONCE PER YEAR MINIMUM)

- All interventions must be carried out by a professional, who will contact the manufacturer if necessary (contact details on the back page of this document).
- All spare parts must come from the manufacturer or comply with standard NF P90-308.
- Check that the installation is working correctly.
- Inspect the cover thoroughly.
- It is necessary to check at the start of every season and if any accident has occurred (if anything has fallen onto the cover, if hail has struck the cover, if the cover has had to bear any abnormal weight etc...) check that none of the slats has sustained any visible damage that may affect the safety of the cover (cracked slats, holes, deformations, etc...). Make sure that you change the slats or the entire cover if required.
- In summer or in winter, do not place an opaque sheet over the cover: this may damage the slats due to high temperature.
- Check the state of the straps (seams) and in particular the wear on the anti-abrasion sleeve. If the latter is no longer fulfilling its role of protecting the strap against abrasions from the pool rim, then replace it.
- Once a year, check that the electrical connections are sufficiently tight.
- Customer service: contact details on back page of document.

SAFETY ADVICE

Dear Customers,

Thank you for placing your trust in us by selecting a safety cover made by DEL.

Please read the recommendations set out below with care.

WARNING

Swimming pools can represent a serious danger for your children. Drowning can happen very quickly.

Children who are close to a swimming pool need to be watched constantly and actively, even if they know how to swim.

Learn lifesaving skills.

The physical presence of an adult is absolutely essential whenever the pool is open.



Memorise the telephone numbers for the emergency services and ensure that they are displayed close to the pool.

☎.....or **112**

FIRE BRIGADE



**AMBULANCE
SERVICE**

(write the number for your region)



**POISON CONTROL
CENTRE**

SAFETY ADVICE

- This section is by no means a replacement for common sense or individual responsibility. Its aim is not to replace the vigilance of parents and/or responsible adults, who remain the essential factor in ensuring the protection of young children.
- **Warning:** safety is only guaranteed when the cover is closed, locked and correctly installed in compliance with the manufacturer's instructions.
- The cover must systematically be closed if you are absent from home, even for a very short period.
- Check that no persons and no foreign objects are in the pool before and during opening and closing operations.
- Make sure that you place all of the tools required for moving the pool cover out of the reach of children (e.g. the key).
- Operation of the mechanism must only be carried out by a responsible adult.
- Climbing, walking or jumping on a pool cover is strictly forbidden.
- Take all necessary measures to prevent access to the pool for young children until the cover is repaired or when a malfunction is observed that prevents closing or in case of temporary unavailability of the equipment or the pool.
- Respect the water levels designated by the manufacturer.

A child can drown in less than 3 minutes, no type of protection can ever replace the watchful eye and vigilance of a responsible adult.

RECYCLING

PACKAGING

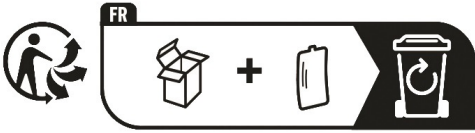

Dispose of the packaging in line with current rules and regulations.

END OF LIFECYCLE



- Do not put your scrapped equipment or used batteries in with unsorted household waste.
- You are responsible for disposing of all of your waste, in particular electrical and electronic equipment by taking it to a collection point where recycling and valorisation are carried out.
- Certain products potentially contain substances that are dangerous for the environment, and you need to ensure that these are eliminated or neutralised.
- Make sure that you are aware of all existing recovery and collection systems.



discard the manual in line with the current regulations.

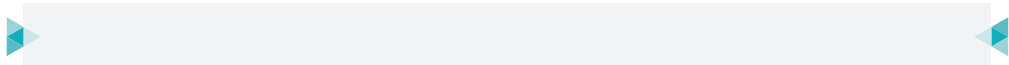

DEL SAS
ZA LA BASSE CROIX ROUGE
35530 BRÉCÉ - FRANCE

☎ +33 (0)9 70 72 5000 / INFO.FR@CF.GROUP

STAMP

A brand by CF group

