

EN



# INSTALLATION GUIDELINES

INSTALLATION/SERVICING/MAINTENANCE/SAFETY ADVICE



DEL 

ABOVE-GROUND COVER

TIXIT

---

# CONTENTS

## **PLEASE READ THESE INSTRUCTIONS CAREFULLY AND KEEP THEM FOR FUTURE REFERENCE**

Please read this manual carefully to help you understand all of the information and to ensure safe installation, use and servicing. We cannot be held liable for any damage arising due to a failure to respect the instructions set out in this manual.

<b>INFORMATION.....</b>	<b>p. 4-5</b>
Electrical and solar-powered version .....	p. 4
Roller .....	p. 5
<b>DESCRIPTION.....</b>	<b>p. 6-7</b>
Components provided .....	p. 6
Tools required for Mounting.....	p. 7
Packing list .....	p. 7
<b>INSTALLATION.....</b>	<b>p. 8-27</b>
Pre-installation information .....	p. 8
Mounting/positioning/fastening .....	p. 9-11
Motor installation .....	p. 12
<b>MOUNTING THE REAR OF THE END-STAND .....</b>	<b>p. 13</b>
Control box.....	p. 14
Wiring for Aqua 11 Control box with Wi-Key .....	p. 15
Wiring for solar-powered version with Wi-Key .....	p. 16
Wiring for Aqua 11 Control box with key switch.....	p. 17
Wiring for solar-powered version with key switch. ....	p. 18
Wi-Key .....	p. 19-21
Setting .....	p. 22
Automatic switch (torque limiter) .....	p. 23-26

# CONTENTS

Pool Sound option .....	p. 27
Mounting the front of the end-stand .....	p. 27
<b>SERVICING/MAINTENANCE.....</b>	<b>p. 28-29</b>
Pool water level.....	p. 28
Water filtration and treatment .....	p. 28
Servicing (customer's responsibility) .....	p. 28
Battery .....	p. 29
Wintering.....	p. 29
Maintenance .....	p. 29
Roller clutch.....	p. 30
<b>SAFETY ADVICE AND STANDARDS .....</b>	<b>p. 31-32</b>
<b>RECYCLING .....</b>	<b>p. 33</b>

## ELECTRICAL AND SOLAR-POWERED VERSION

Opening and closing manoeuvres can be carried out by one person and take around 2 minutes and around 3 minutes for locking and unlocking the fastening kit.

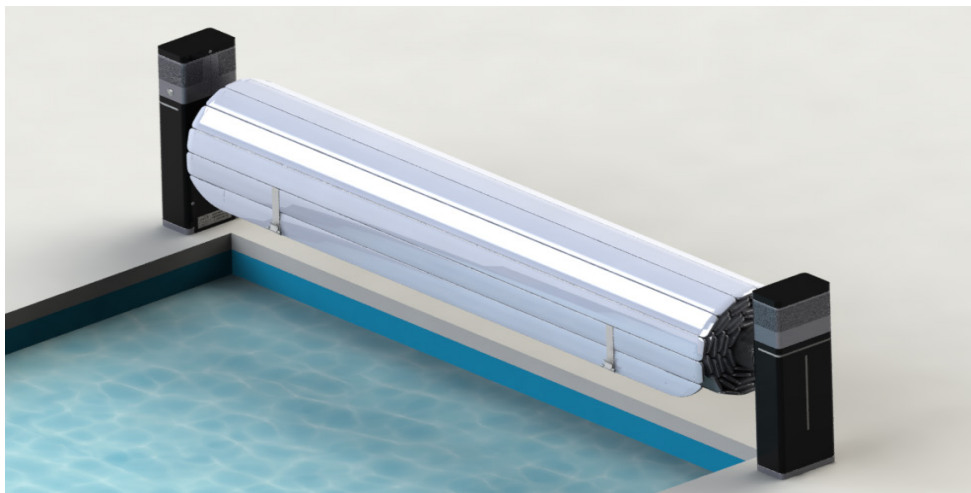
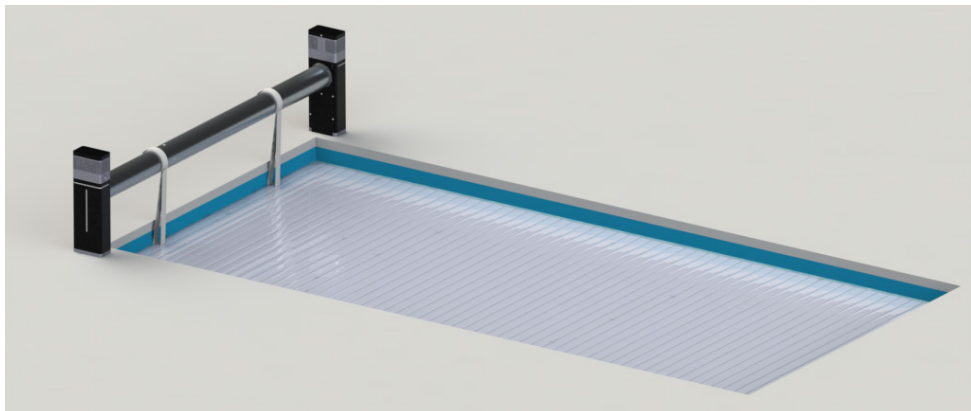

- ❗ • On mirror or infinity pools, DEL covers do not comply with French standard NF P90-308 unless the pool is equipped with a Vitalia INFINITY control box to automatically lower the water level by at least 2cm when the pool cover is closed.
- Currently, DEL covers including a removable slats for step unit on the length to go over a ladder do not comply with standard NF P90-308
- Unless the alarm manufacturer indicates otherwise, immersion alarms are not compatible with DEL covers.

# INFORMATION

## ROLLER



	<ul style="list-style-type: none"> <li>• The motor (which complies with electrical standards) is located in the tube and can be accessed from inside the end-stand..</li> <li>• The “mechanical “end-of-runs” allowing the cover to be stopped when it is fully open or rolled onto the tube can be directly adjusted on the motor.</li> </ul>
	<p><b>Control:</b></p> <ul style="list-style-type: none"> <li>• Wi-Key or</li> <li>• Key switch</li> </ul>
	<ul style="list-style-type: none"> <li>• For the electrical version: The control box is installed in the technical room close to the pool.</li> </ul>
	<ul style="list-style-type: none"> <li>• For the solar powered version: The solar panels and the batteries are integrated into the terminal.</li> </ul>

### Optional:

	<ul style="list-style-type: none"> <li>• Electrolyser coupling (electrical version only): “Stop salt” control box : connected to the control box of the cover and the electrolyser and is used to automatically reduce the production of chlorine when the pool is closed.</li> </ul>
	<ul style="list-style-type: none"> <li>• Automatic switch (torque limiter): protects the system if anything is forgotten during the unlocking process (fastening kits or other), when the opening the pool cover. If the cover is blocked, the motor will stop automatically.</li> </ul>
	<p>Pool Sound: Allows you to listen to music thanks to the covers’ end-stands.</p>

# DESCRIPTION

## COMPONENTS PROVIDED

### END-STANDS

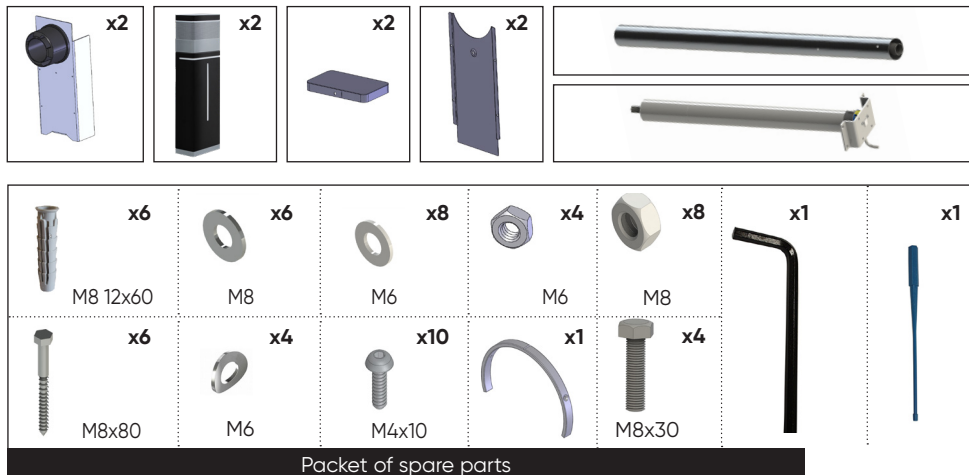

### CONTROL BOX AND CONTROL MANAGEMENT

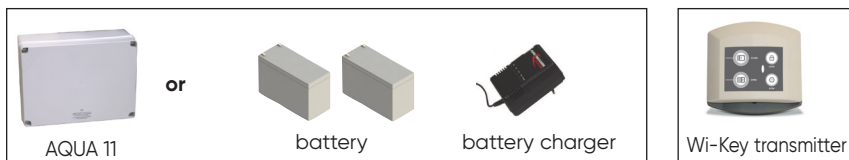

### OPTIONS

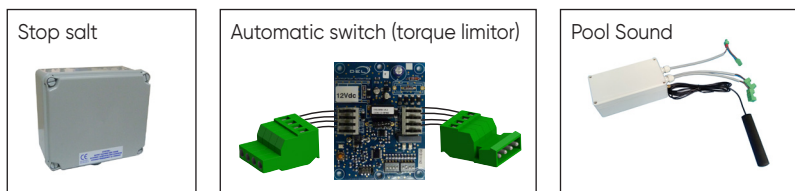

# DESCRIPTION

## TOOLS REQUIRED FOR MOUNTING



## PACKING LIST

### Example for a 4x8m pool:

1 parcel - 0.80 x 0.60 x 0.55m 40kg

1 parcel - 4.30 x 0.20 x 0.20m 25kg

4 parcels - 4.10 x 0.25 x 0.20m 150kg

**Total weight : 215kg**

## MOUNTING



**2 people**



**3 hours**

# INSTALLATION

## PRE-INSTALLATION INFORMATION

### ELECTRICAL VERSION

Remember to place a conduit for the wiring to connect the Control box with the motor terminal.

See positioning rules 1 page 10

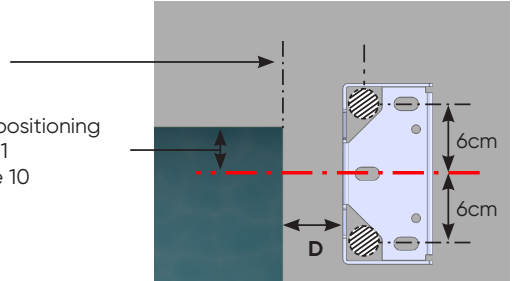

$$D = (\text{distance between terminals} - \text{pool width}) / 2$$

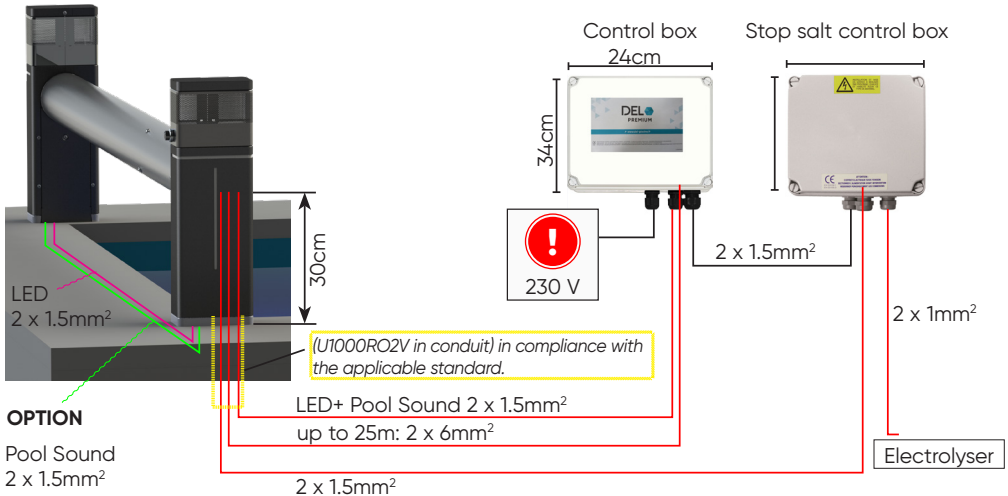

### SOLAR-POWERED VERSION

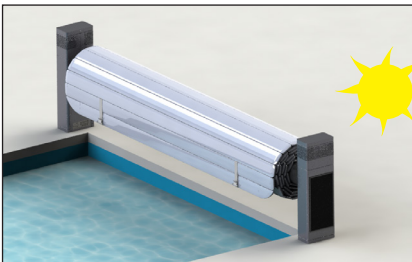

Place the solar collector on the side that gets the most sunshine.



# INSTALLATION

## MOUNTING/POSITIONING/FASTENING

### MOUNTING

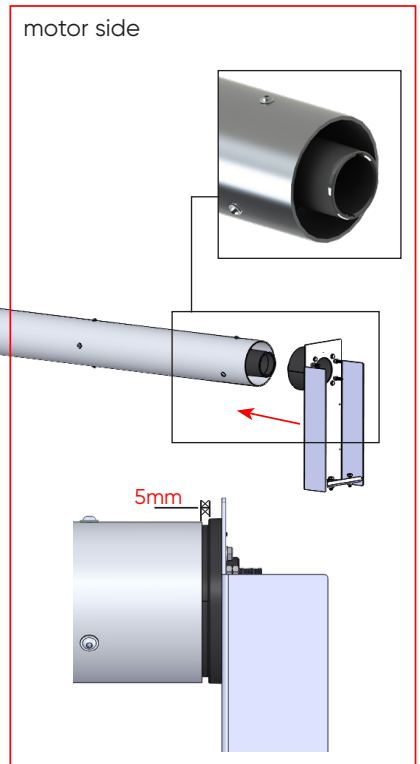
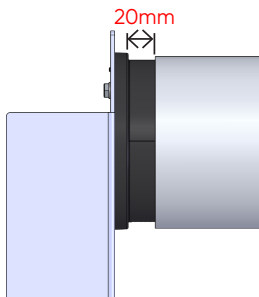
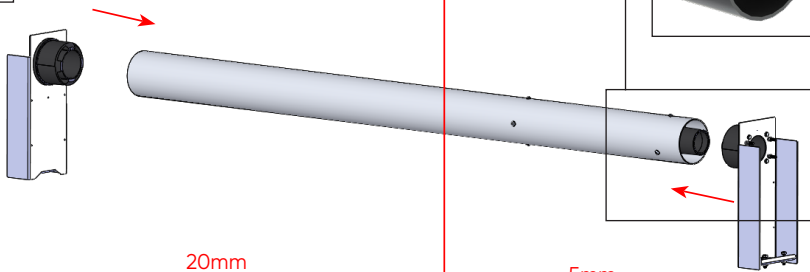
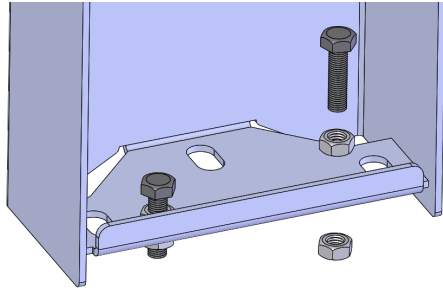
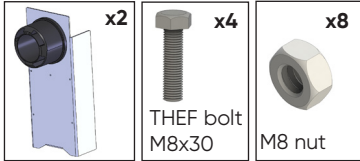

# INSTALLATION

## POSITION 1

Depending on the corner angles of the pool and fastening kits on the roller side

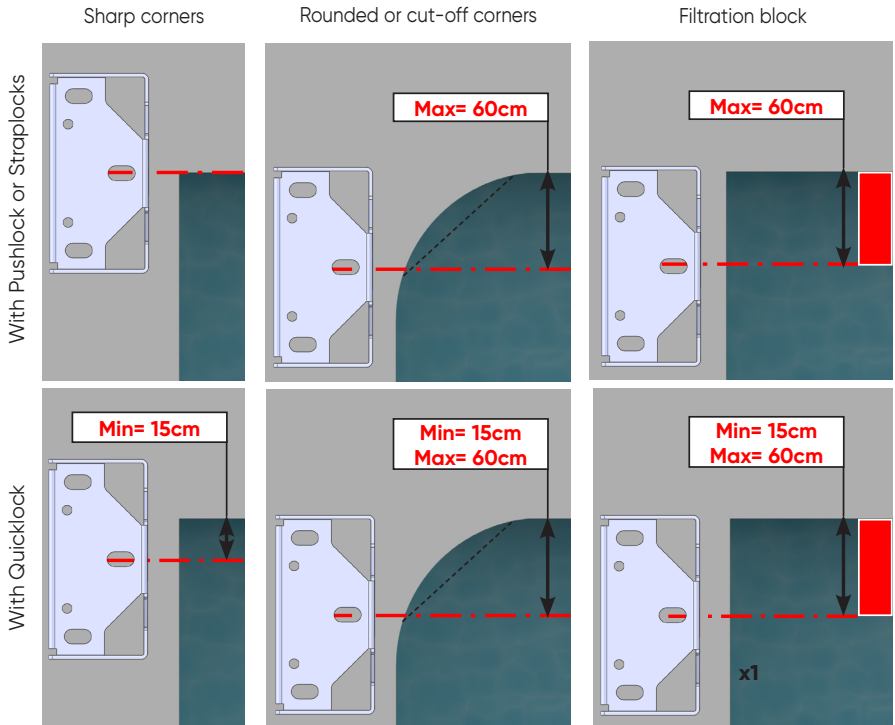

## POSITION 2

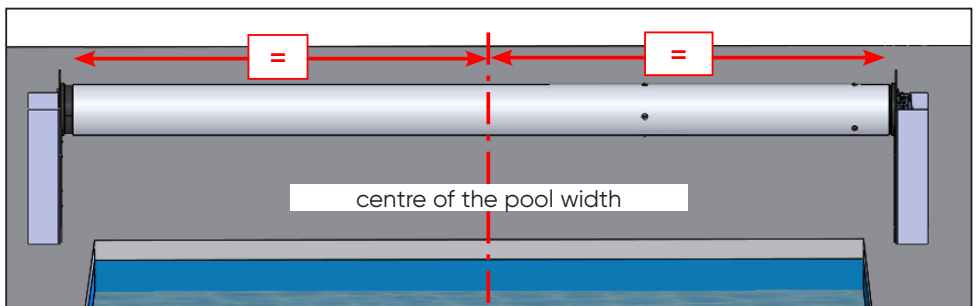

# INSTALLATION

## LEVELLING THE TUBE

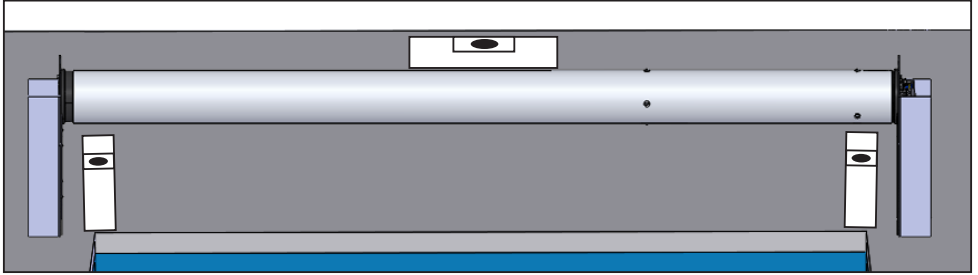

## FASTENING AND ADJUSTMENT

Fasten the clamp ring.

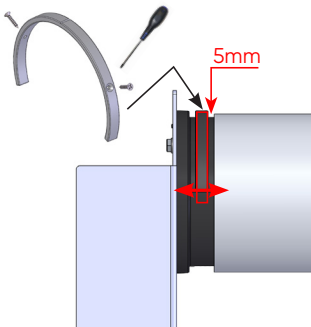

motor side

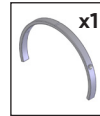
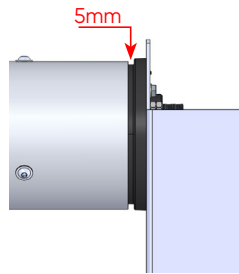

Before fastening, ensure that you have 5mm clearance on the side on both sides.

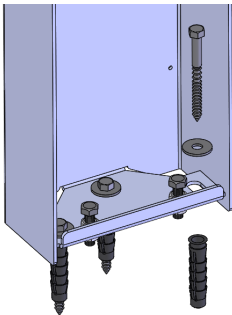

# INSTALLATION

## MOTOR INSTALLATION

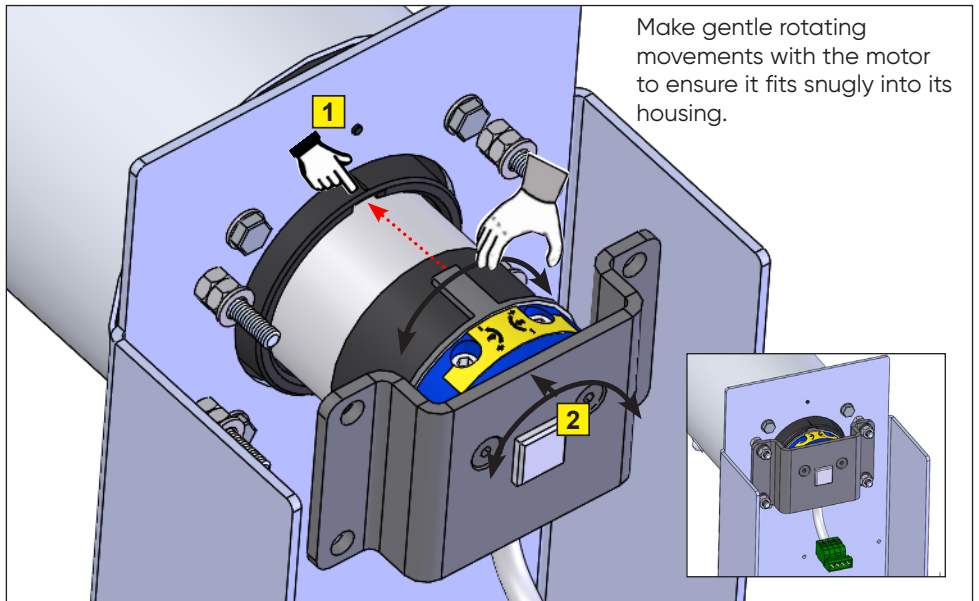
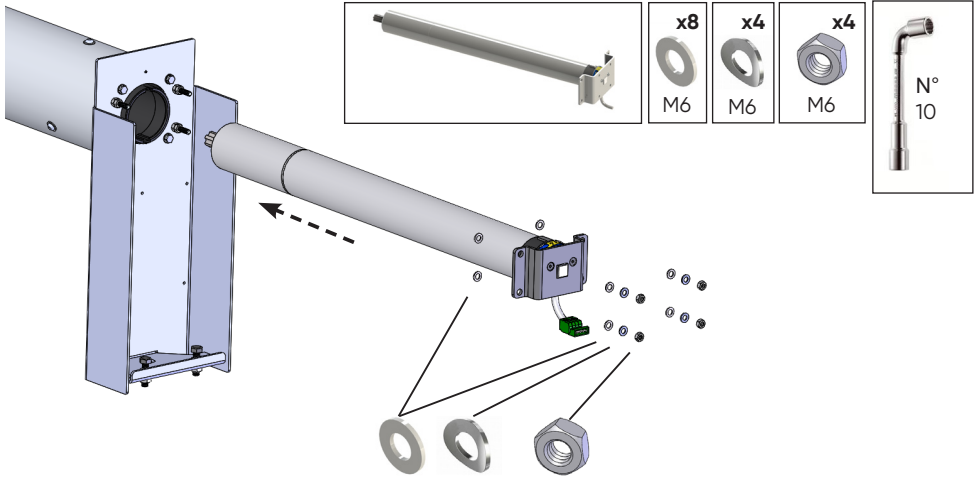

# INSTALLATION

## MOUNTING THE REAR OF THE END-STAND

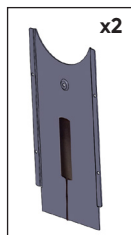
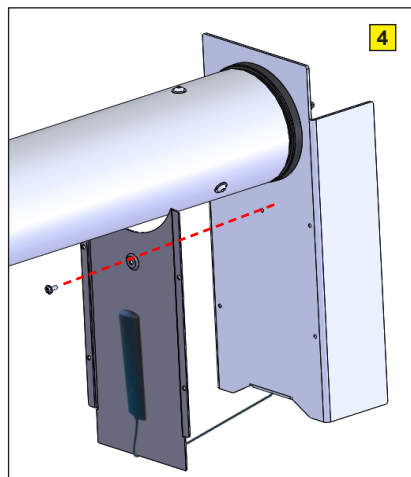
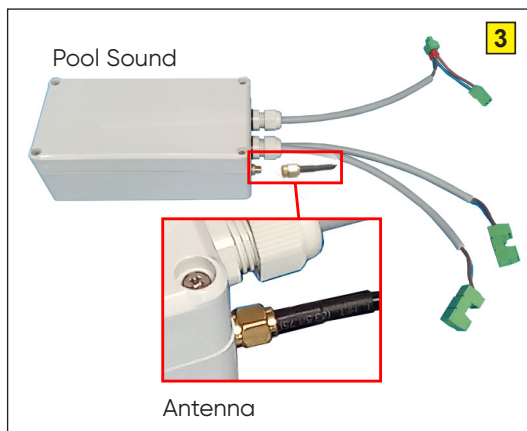
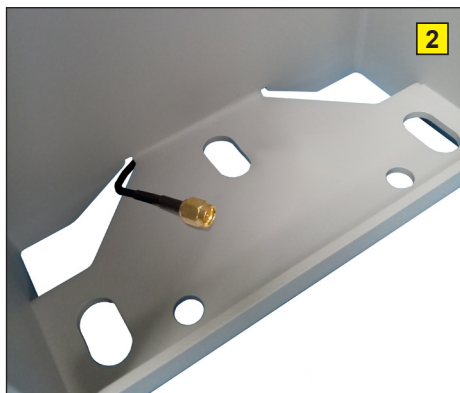
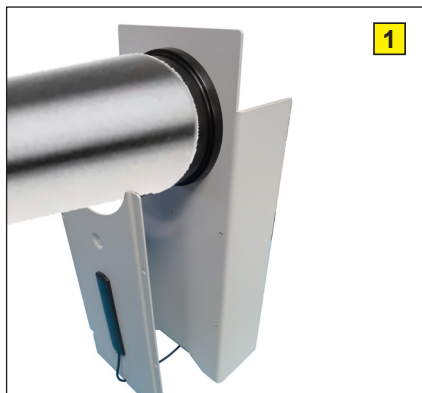

# INSTALLATION

## ELECTRICAL CONTROL BOX

### ➤ MOUNTING THE CONTROL BOX

- The control box must be fixed to the wall of the equipment room in an easily accessible position, between 1 metre and 1.80 metres above the floor.
- The box must be securely fixed to the wall using the screws and plugs supplied with it.
- Caution: if you decide to fix your enclosure by any other means, please ensure that it is securely fixed, as the guarantee may not apply. Please note that adhesives are not considered to be a reliable means of fixing.

# INSTALLATION

The electrical connection of the equipment must only be carried out by a qualified professional, and they must comply with the manufacturer's instructions in addition to the following applicable standards and regulations:

- NF C15-100: Low voltage electrical installations
- CEI 60364: Electrical installations for buildings

Please refer to the leaflet enclosed with the cabinet to ensure correct installation.



Incorrect installation may result in an electric shock, or it may even damage the equipment. We recommend that you disconnect the cabinet prior to any work being carried out on it.

Any specific electrical supply line must be protected by a 30mA circuit breaker along with a sufficient overcurrent protection device.

We recommend use of shielded cable with a nominal cross-section that is not lower than the one indicated in the following table:

Current specified for the equipment A	Nominal cross-section mm <sup>2</sup>
≤0.2	Flat twin tinsel cord a
> 0.2 and ≤ 3	0.5 a
> 3 and ≤ 6	0.75
> 6 and ≤ 10	1.0 (0.75) b
> 10 and ≤ 16	1.5 (1.0) b
> 16 and ≤ 25	2.5
> 25 and ≤ 32	4
> 32 and ≤ 40	6
> 40 and ≤ 63	10

NOTE: For power cables supplied with polyphase equipment, the nominal cross-section of the conductors is based on the maximum cross-section of the phase conductors at the end of the power cable that is intended to be connected to the terminals of the unit.

- a These cables can only be used if their length, as measured between the point where the cable or cable protector enters the equipment and the connection to the mains supply, does not exceed 2m.
- b Cables that have the cross-sections indicated in brackets can be used for mobile equipment if their length does not exceed 2m.

# INSTALLATION

## WIRING FOR AQUA 11 CONTROL BOX WITH WI-KEY

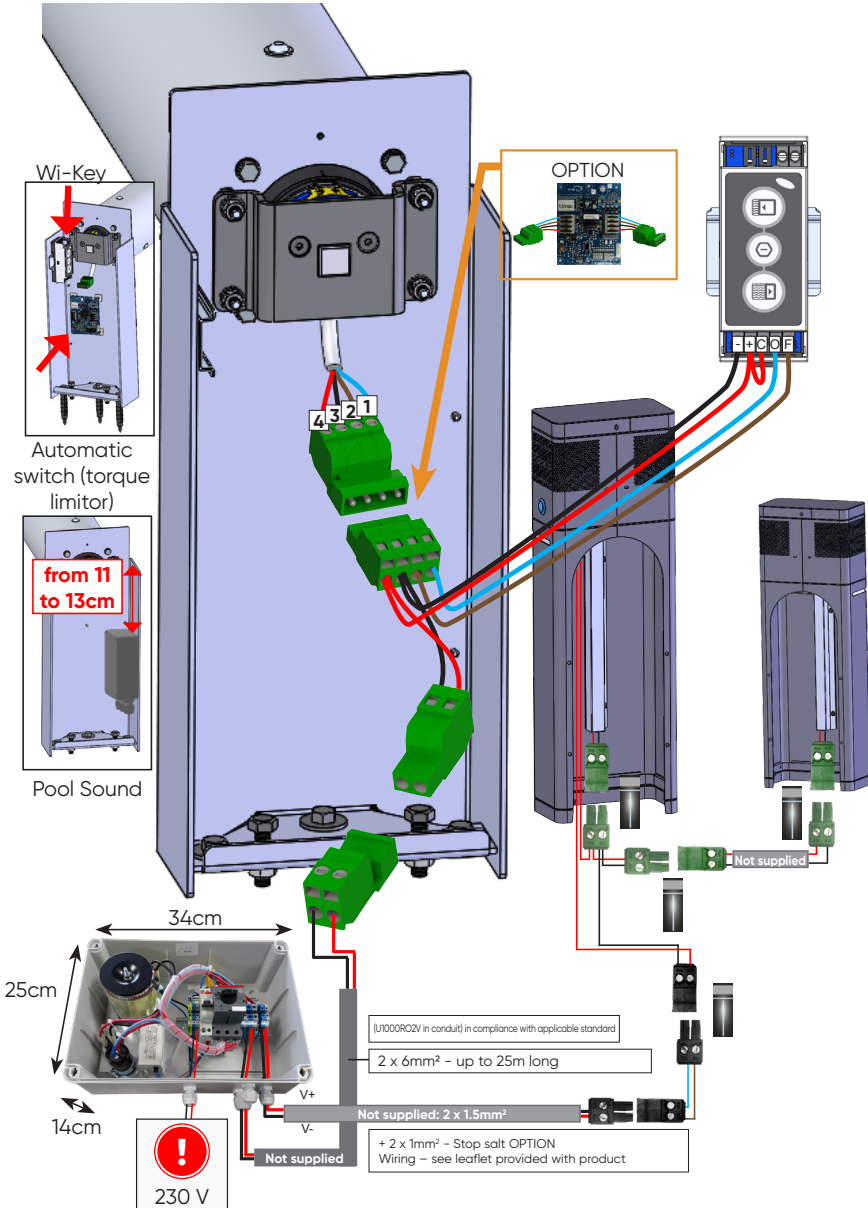



# INSTALLATION

## WIRING FOR AQUA 11S CONTROL BOX WITH WI-KEY - SOUND OPTION

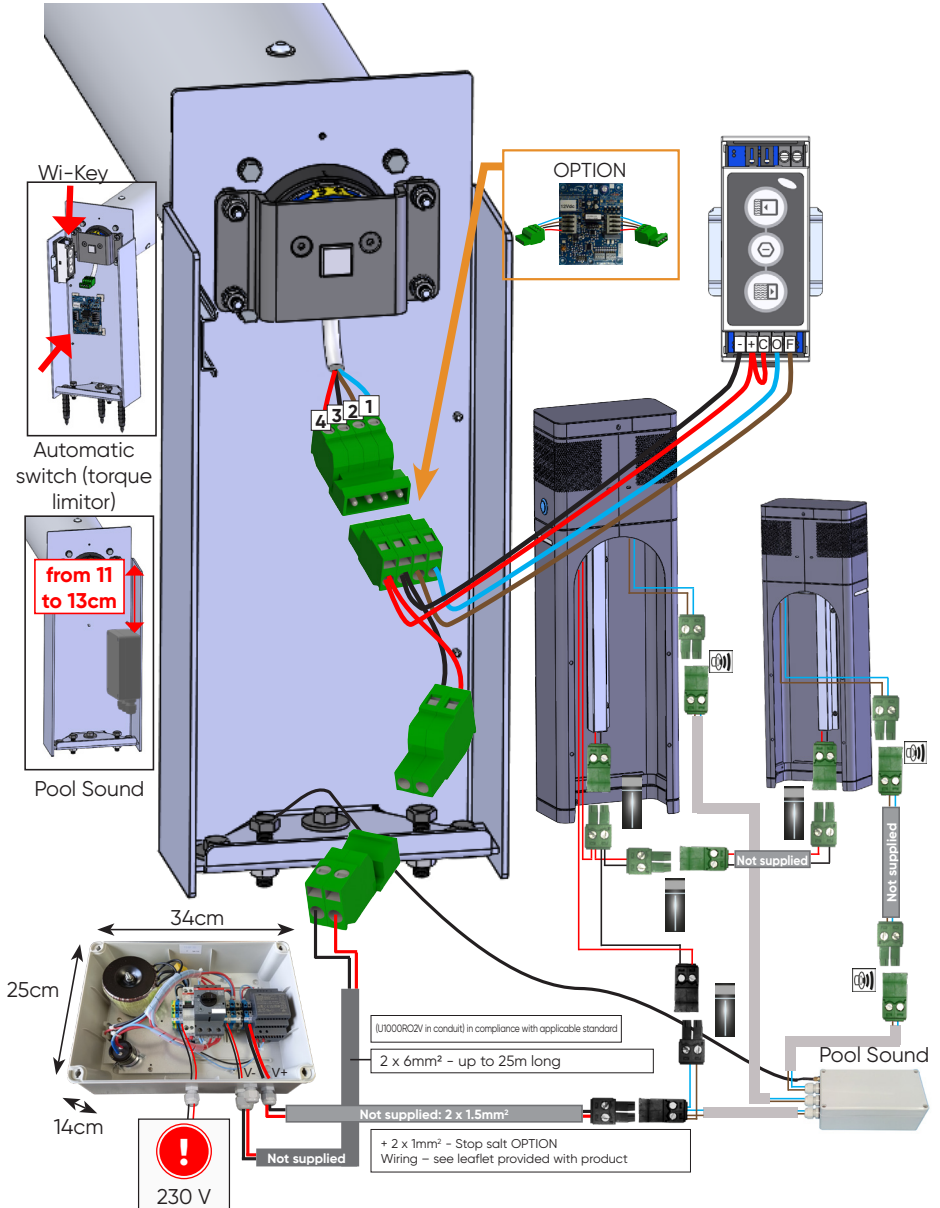

# INSTALLATION

## WIRING FOR SOLAR-POWERED VERSION WITH WI-KEY

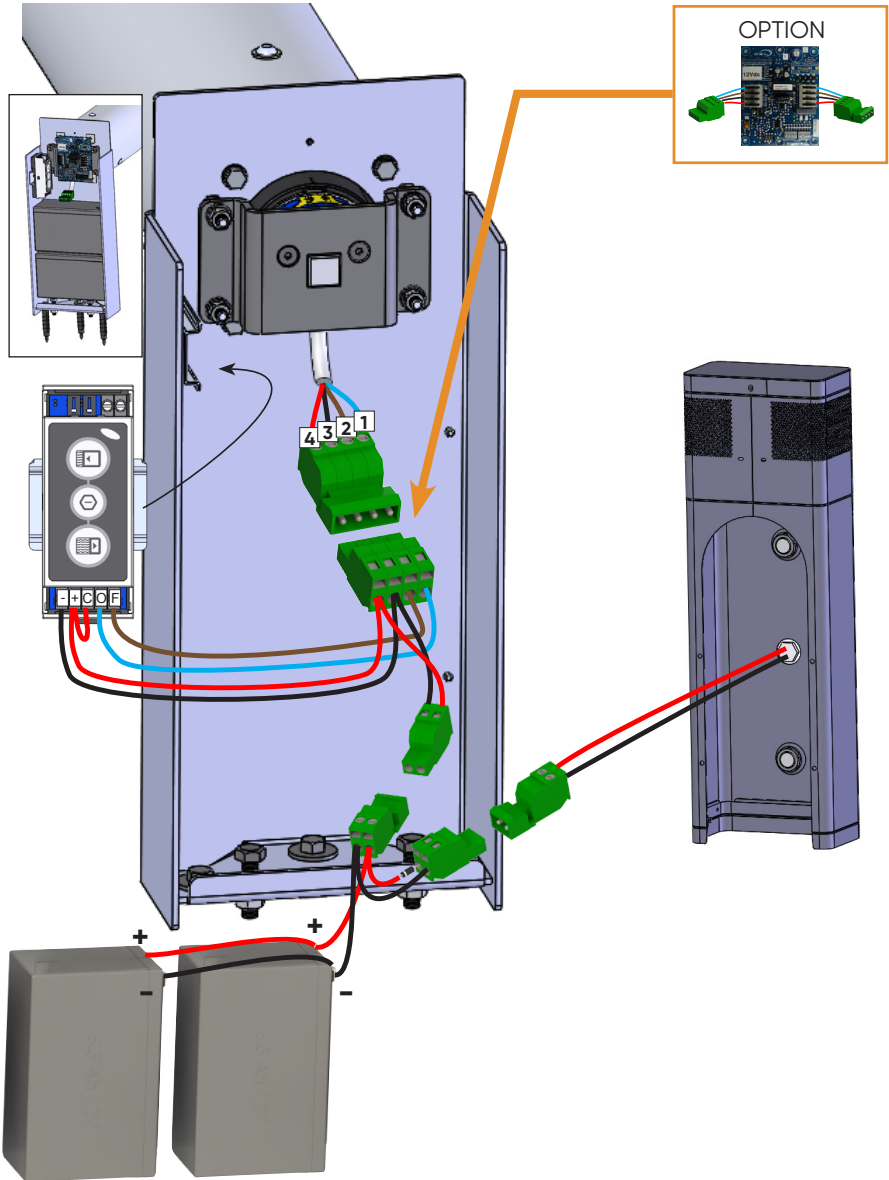

# INSTALLATION

## WIRING FOR AQUA 11 CONTROL BOX WITH KEY SWITCH

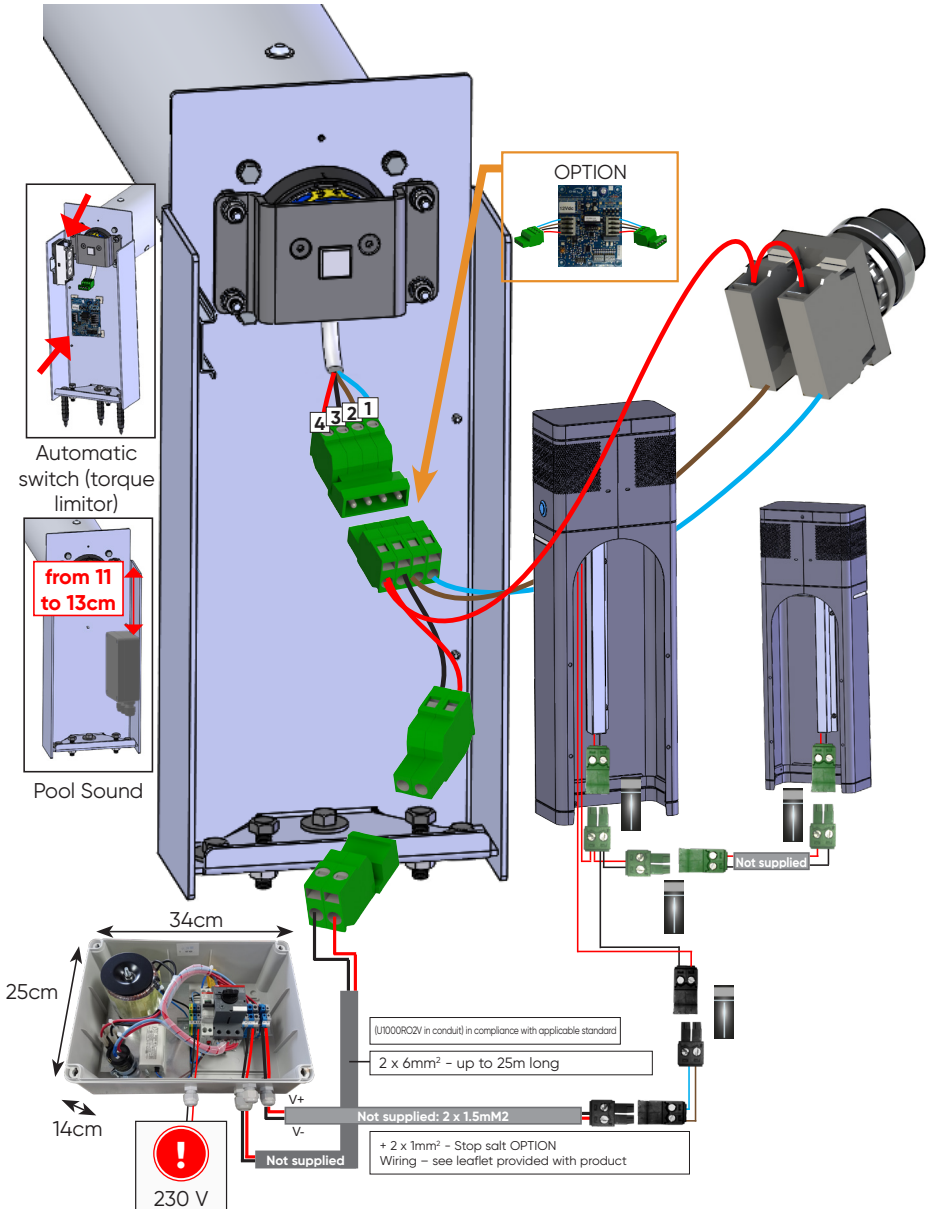

# INSTALLATION

## WIRING FOR AQUA 11S CONTROL BOX WITH KEY SWITCH - SOUND OPTION

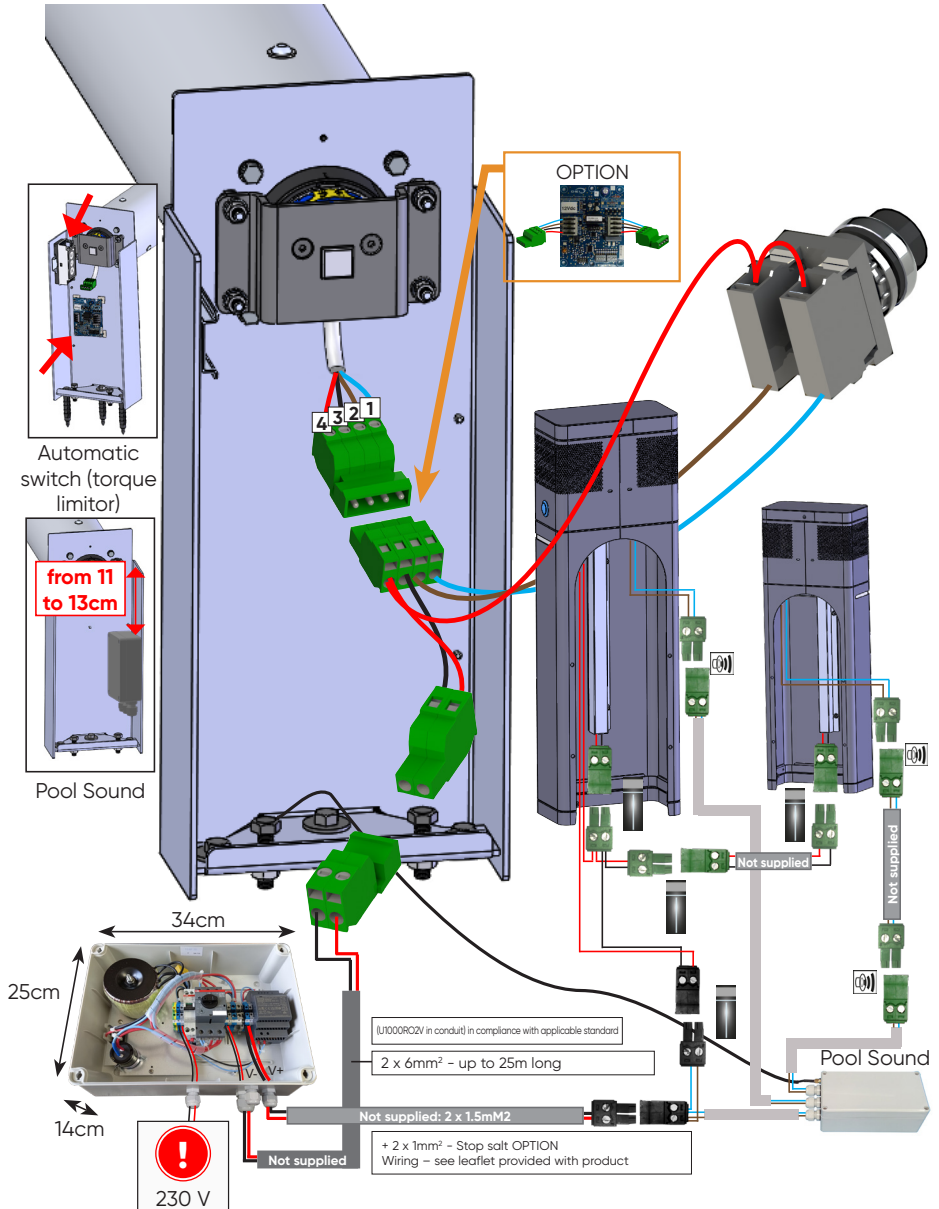

# INSTALLATION

## WIRING FOR SOLAR-POWERED VERSION WITH KEY SWITCH.

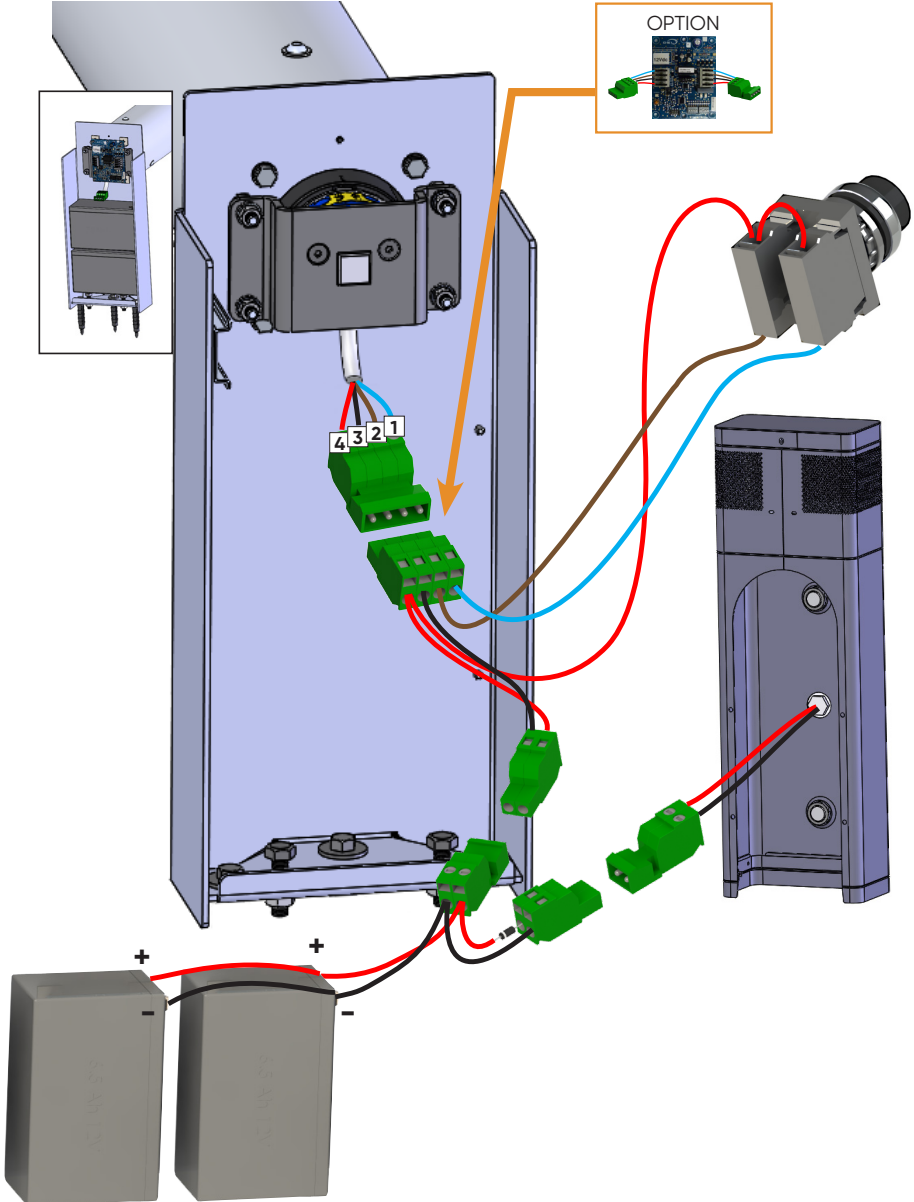



# INSTALLATION

## WI-KEY



Flashing green/red = transmitter locked  
See transmitter unlocking procedure page 24.

	 Receiver	 Transmitter
Manufacturer	DEL	DEL
Reference	Wi-Key receiver	Wi-Key Transmitter
Category	3 (NF EN 300220-1)	3 (NF EN 300220-1)
Range	50m open field range	50m open field range
	25m through a concrete wall	25m through a concrete wall
Power supply	12 to 48Vcc 30mA max	2 x 1.5V AAA batteries
Protection rating	IP40	IP54

The transmitter must be set outside of the volume 0 position.  
(volume 0 is the part that is underwater, even if immersion is temporary).

The distance between the transmitter and the receiver must not exceed:

- 50m open field range.
- 25m behind a single wall.
- 15m behind several walls or a particularly thick wall.

Frequency bands used by the transmitter-receiver: 868MHz to 868.6MHz  
Maximum power of the radiofrequency: 10mW

We advise you to check the transmitter-receiver connection prior to fastening the elements into place.

# INSTALLATION

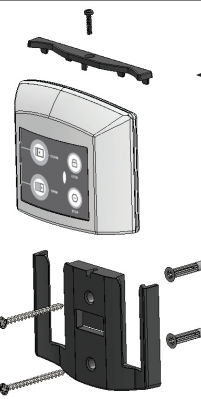

• It must be located in a place that allows the user to check that no-one is in the pool during the operation.

- The "locking bar" has to be installed and bolted into place.
- Before fixing the emitter to the wall, ensure that the transmitter is communicating with the receiver.

← The support must be fastened on to a wall.



Close



Open



Lock keypad



Stop current operation

## ▶ PAIRING A NEW TRANSMITTER

### Receiver

1

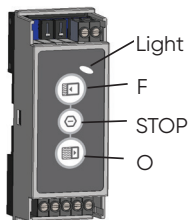

Light indicator

F

STOP

O

Press "STOP" and hold the button down, then press "O" for more than 3 seconds OK when the "Light indicator" flashes green.

Pairing of a new transmitter must be carried out within the following 30 seconds.

### Transmitter

2



F

Light indicator

O

STOP



Press "STOP" and hold the button down, then press "O" for more than 3 seconds OK when the Light indicator flashes red/green.

Pairing of a new transmitter must be carried out within the following 30 seconds.

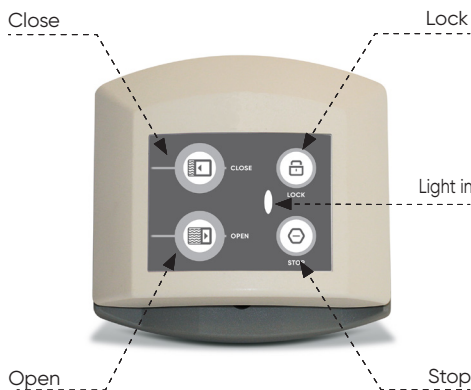





# INSTALLATION



## ▶ LOCK WI-KEY



- Press  for more than 3 seconds until the  Light indicator flashes  = system locked

## ▶ UNLOCK WI-KEY

- Press  and hold
- At the same time: press successively on the following three buttons:  
  
- The  Light indicator remains lit  = transmitter unlocked

## ▶ LIGHT INDICATORS

When you press a button, the Light indicators below will inform you of the status (locked/unlocked) of the Wi-Key, as well as the charge level of the batteries.

	Green LED		Wi-Key unlocked
	Flashing green/red LED		Wi-Key locked
	Orange LED		Battery level low
	Red LED		Change batteries (2 x LR03)



# INSTALLATION

- ❗ Any person carrying out work on the electrical parts must be qualified and wear PPE (personal protective equipment): gloves, goggles, mat, etc.
- ❗ Warning: use of the pool cover control buttons present in the housing (Wi-Key receiver) must only be carried out by a person who is absolutely certain that there is no risk and that no-one will enter the pool during the operation.

## SETTINGS

### CHECK

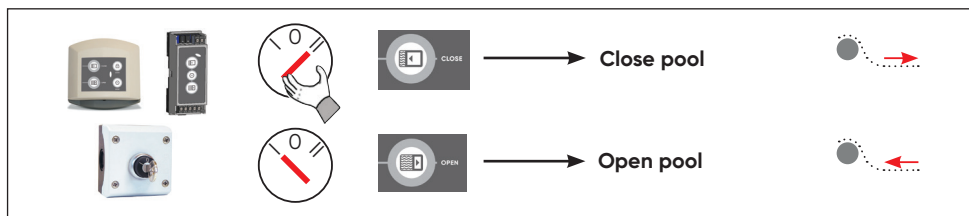

If the control logic is not respected, check the wiring of the installation.

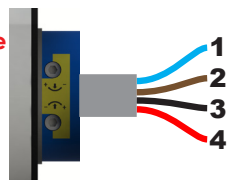

### PROGRAMMING THE LIMIT SWITCHES

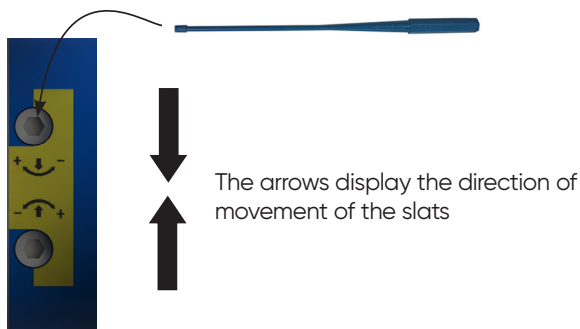
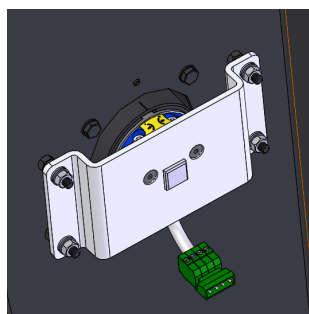

By turning in the + direction, you will increase the range of movement of the cover.  
By turning in the - direction, you will decrease the range of movement of the cover.

# INSTALLATION

## AUTOMATIC SWITCH (TORQUE LIMITOR)

The Automatic switch (torque limiter) protects the system from any potential oversights with regard to the unlocking of the fastening kits when the pool is opened. If the cover is blocked, the motor will stop automatically.

### The different reasons for a blockage:

- Fastening kits have not been unlocked.
- The cover is rubbing ; on the beam, on the copings, ...
- Presence of an object in the pool (robot, counterweight...) that is blocking the cover.

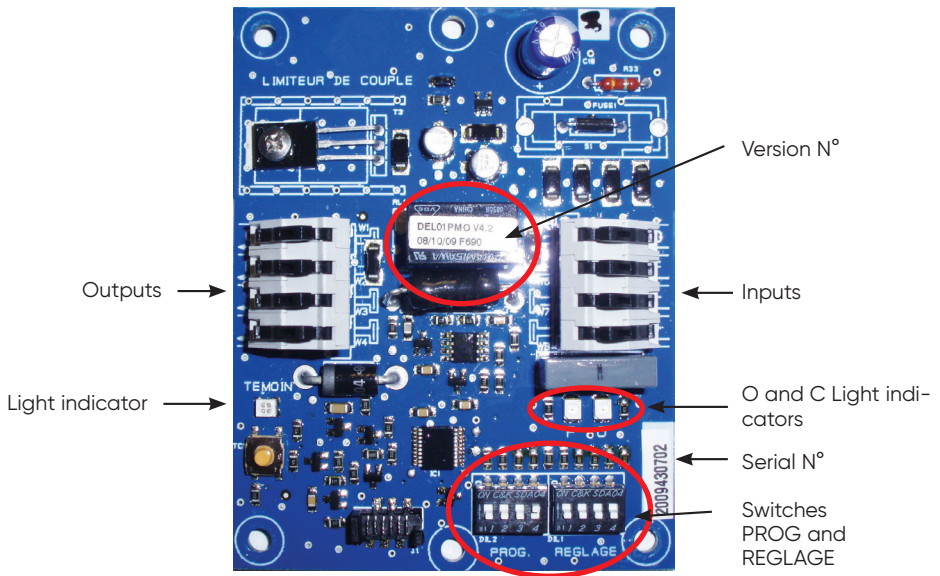

# INSTALLATION

## ▶ CHECK THE CONTROL LOGIC

- Deactivating the Automatic switch (torque limiter) (PROG)



deactivated



- Check :



Close pool



Light indicator

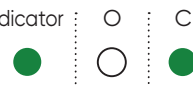

Open pool



Light indicator



**⚠ If the control logic is not respected, check the wiring of the installation.**

## ▶ CONTROL DURATION ADJUSTMENT

L = pool length including stairs

$L \leq 12$  m



30 seconds

$L > 12$  m



60 seconds



# INSTALLATION

## TRIGGERING SENSITIVITY ADJUSTMENT

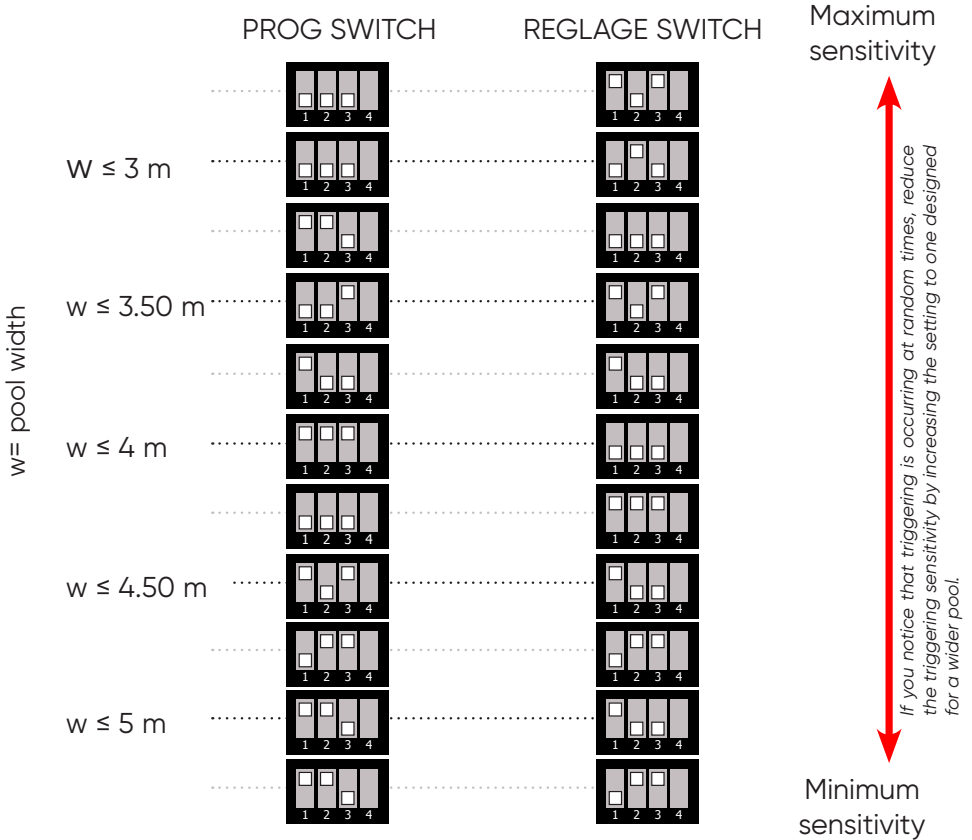

# INSTALLATION

## ACTIVATION OF THE AUTOMATIC SWITCH (TORQUE LIMITOR)



↓ activated

**Failure to activate the Automatic switch (torque limiter) can cause serious damage to the motor, the Control box and the slats, which will affect the warranty.**

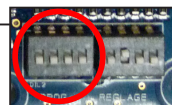

## TEST

**A** - Block the cover manually or with the locking kits and open it while watching the pool.

**=> The motor is stopped automatically** (if required, adjust the triggering sensitivity).

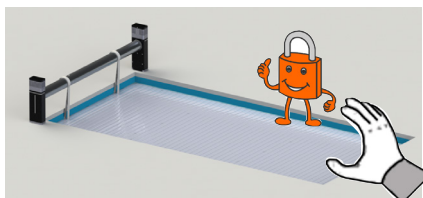

*If you notice that triggering is occurring at random times, reduce the triggering sensitivity by increasing the setting to one designed for a wider pool.*

ACTIVITY CARD	LIGHT INDICATORS	o	c	
	Opening, check underway			
	Opening without control			
	Closing			
	Protection triggered			

## INFORMATION

The cover stops when the pool is being opened:

### 1 – Stoppage due to a genuine blockage

(failure to unlock safety locking kits or any other reason):

- Close for more than 3 seconds until the slats are no longer stretched.

**The next attempt to open it will remain protected by the system.**

- Remove the cause(s) of the blockage(s) and restart the opening procedure.

### 2 – Unintentional shutdown

- Close for 1 to 3 seconds

**The next attempt to open it will no longer be protected by the system.**

- Try to open the pool again.
- If shutdowns are being triggered at random times, reduce the sensitivity of the board.
- If the motor is being overexerted before triggering occurs, increase the sensitivity of the board ("triggering sensitivity" setting).

Opening protected



Opening not protected



# USE

## POOL SOUND OPTION

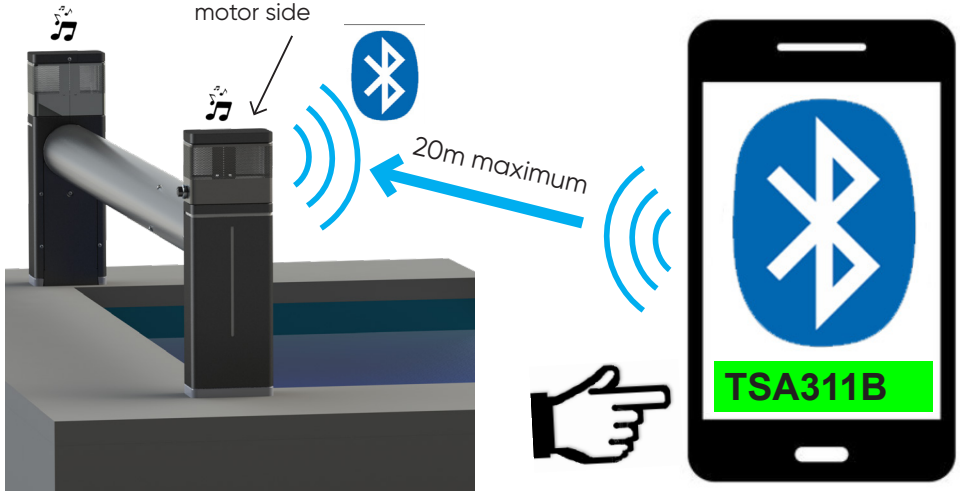

## MOUNTING THE FRONT OF THE END-STAND

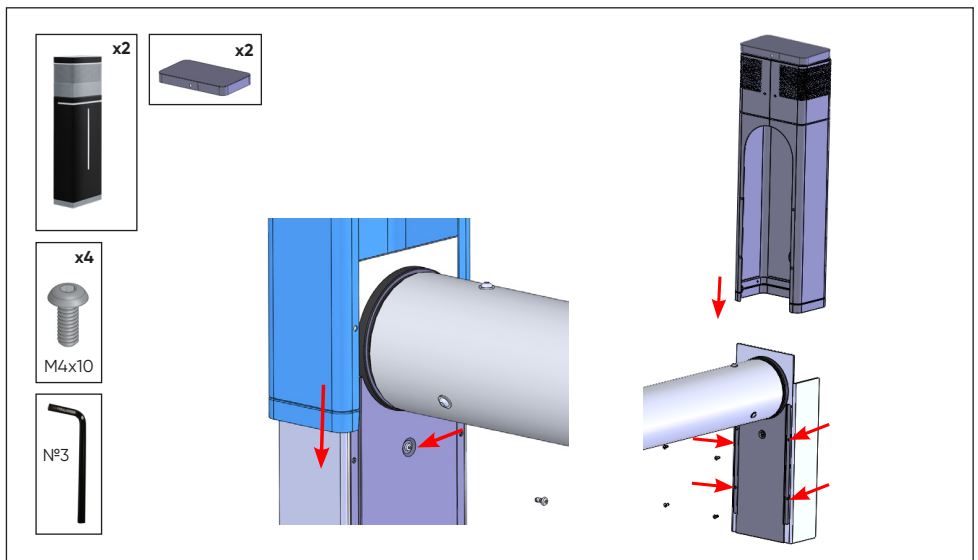

# SERVICING/MAINTENANCE

## POOL WATER LEVEL

- In order to ensure maximum safety and correct operation of the Roller, always check that the water level in the pool remains constant and complies with the manufacturer's requirements (for greater comfort, use an overflow and a water level regulator).
- A water level that is too high is due to the overflow being obstructed by leaves or other items.
- A water level that is too low means that there is a risk of blockage.
- In case of a recess or a handrail, the water level must be controlled by a level regulator.

## WATER FILTRATION AND TREATMENT

- Program filtration to take place at a time when the sun is shining on the pool and ensure that it is set to work continuously when the water reaches 28°C.
- In order to ensure that your installation will last, the water in the pool must be correctly treated in compliance with the applicable standards and recommendations (NF EN 16713-3).
- The pH, hardness and alkali levels of the water must be checked and adjusted as often as is necessary (although you will need to ensure that you don't correct these three parameters independently of each other but do so using the Taylor table and balance the water with regard to the three parameters analysed).

## SERVICING (customer's responsibility)

- Carry out a deep clean of the slats twice per year (the first time in the year it is used and prior to wintering). This is even more important if the water in the pool is hard. To do so, use a pressure washer with hot water and a descaling cleaning product (Décalcit super).
- Also ensure that you regularly clean the fastening kits especially the anchor to avoid it getting stuck. We recommend annual greasing of the anchor to ensure that the system works as well as possible.
- It is best to inspect the entire system if the cover is forced to bear unexpected weight at any time (if anything falls on it).
- Carry out an annual check of the straps.
- For optimal solar sensor performance, clean it regularly using a window cleaning product.

# SERVICING/MAINTENANCE

## BATTERIES

At the first sign of the batteries losing power, recharge them.

**NEVER LET THE BATTERIES LOSE COMPLETELY THEIR CHARGE.**



Always disconnect the solar sensors beforehand then disconnect the batteries.

Connect the batteries to the charger (check the polarity). Plug the charger in. It will switch on automatically to the correct voltage and the charging process will begin. The red LED shows that charging is underway. When the charge is complete, the red LED will be switched off and the batteries are then powered by a maintenance charge (see charger instructions).

Precaution: Keep your charger in a dry place. Do not recharge the batteries close to the pool, but instead do so in a dry place.

Minimum recharging time: 48 hrs

## WINTERING

- Overwinter the pool in the best way with regard to its geographical situation.
- Close the cover into the safety position.
- Leave the batteries in the Roller and do not cover the solar panel.
- We recommend the installation of an Ivern a wintering cover or an Ivern a Plus protective cover to protect the slats from UV rays and dirt.

## MAINTENANCE

- All interventions must be carried out by a professional, who will contact the manufacturer if necessary.
- All spare parts must come from the manufacturer or comply with applicable standards.
- Inspect the cover thoroughly.
- It is necessary to check at the start of every season and if any accident has occurred (if anything has fallen onto the cover, if hail has struck the cover, if the cover has had to bear any abnormal weight etc...) check that none of the slats has sustained any visible damage that may affect the safety of the cover (cracked slats, holes, deformations, etc...). Make sure that you change the slats or the entire cover if required.
- In summer or in winter: do not place an opaque sheet over the cover: this may damage the slats due to high temperature.
- Check the state of the straps (seams) and in particular the wear on the anti-abrasion sleeve. If the latter is no longer fulfilling its role of protecting the strap against abrasions from the pool copings, then replace it



## ROLLER CLUTCH

If the motor breaks down or if there is a power cut, you can remove the motor in order to close the pool manually.

1. Cut off electrical power
2. Disconnect the motor
3. Remove the mountings and pull out the motor
4. Unroll the slats manually.
5. Attach the locking kits.

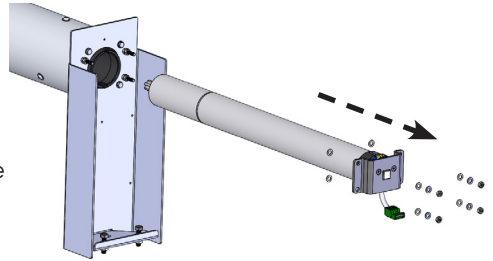

## SERVICING/MAINTENANCE

### WINTERING

- Position the cover in the closed position and keep the water level constant in accordance with the manufacturer's recommendations.

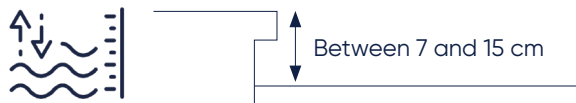

- During the winter season, in the event of snowfall, it is essential to remove the snow from the cover using a brush with a telescopic handle to avoid deforming the crossbars.

### SPARE PARTS

Online catalogue :



<https://www.my-cfgroup.fr/fr/pieces-detachees>

## SAFETY ADVICE

Dear Customers,

Thank you for placing your trust in us by selecting a safety cover made by DEL.

Please read the recommendations set out below with care.

### WARNING

**Swimming pools can represent a serious danger for your children. Drowning can happen very quickly.**

**Children who are close to a swimming pool need to be watched constantly and actively, even if they know how to swim.**

**Learn lifesaving techniques.**

**The physical presence of an adult is absolutely essential whenever the pool is open.**



Memorise the telephone numbers for the emergency services and ensure that they are displayed close to the pool.

☎.....or **112**

**FIRE BRIGADE**



**AMBULANCE  
SERVICE**

(write the number for your region)



**POISON CONTROL  
CENTRE**

## SAFETY ADVICE

- This cover is by no means a replacement for common sense or individual responsibility. Its aim is not to replace the vigilance of parents and/or responsible adults, who remain the essential factor in ensuring the protection of young children.
- **WARNING:** safety is only guaranteed when the cover is closed, locked and correctly installed in compliance with the manufacturer's instructions.
- The cover must systematically be closed if you are absent from home, even for a very short period.
- Check that no people and no foreign objects are in the pool before and during opening and closing operations.
- Make sure that you place all of the tools required for moving the pool cover out of the reach of children (e.g. the key).
- The operation of the mechanism must only be carried out by a responsible adult.
- Climbing, walking or jumping on a pool cover is strictly forbidden.
- In the following cases, take all necessary precautions to prevent young children from accessing the pool :
  - if you are waiting for repairs
  - if you notice any malfunction
  - if you cannot close or secure the pool
  - if the equipment is temporarily unavailable
- Respect the water levels indicated by the manufacturer.

A child can drown in less than 3 minutes, no type of protection can ever replace the watchful eye and vigilance of a responsible adult.

# RECYCLING

## PACKAGING

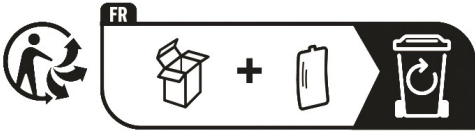

Dispose of the packaging in line with current rules and regulations.

## END OF LIFECYCLE



- Do not put your scrapped equipment or used batteries in with unsorted household waste.
- You are responsible for disposing of all of your waste, in particular electrical and electronic equipment by taking it to a collection point where recycling and valorisation are carried out.
- Some products may contain substances that are dangerous for the environment. You need to ensure that these are eliminated or neutralised.
- Make sure that you are aware of all existing recovery and collection systems.



discard the manual in line with the current regulations.

## REGULATIONS

### STANDARD

- This cover complies with standard NFP 90-308.

### WARRANTY CONDITION

log on to [www.del-piscine.fr](http://www.del-piscine.fr) to consult all our guarantees.



<https://www.del-piscine.fr/rechercher-une-garantie>

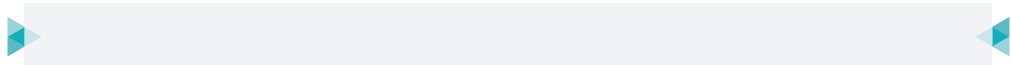

**DEL SAS**  
ZA LA BASSE CROIX ROUGE  
35530 BRÉCÉ - FRANCE

☎ +33 (0)2 99 00 17 72

STAMP

a brand by

